

JSC Motor Sich

# Milk cream separator

Motor Sich SCMR-80-09

User's manual

2016

Electrically driven milk cream separator, hereinafter referred to as the “the centrifuge”, with a productivity rate of min. 80 l/h is designed for whole milk separation into cream and skimmed milk with simultaneous cleansing. The company continues to improve design and in this connection the design of separate parts and assembly units may differ from those specified in the passport. These differences improve quality of the centrifuge as well as its operation.

## 1. SPECIFICATION

1.1. Milk productivity rate, l/h, min	80
1.2. Drum rotation frequency, rev/min	10500±1000
1.3. Number of plates in the drum, pieces	10...12
1.4. Milk receiver capacity, l	12
1.5. Fat content of skim milk, %, max.	0.05
1.6. Regulation of volumetric proportion of fat towards skim milk	from 1:4 to 1:10
1.7. Separated milk temperature, °C	35...40
1.8. Overall dimensions, mm, max.	
bowl diameter	365
height	520
1.9. Centrifuge weight, kg	7.5

## 2. COMPLETE SETS

The centrifuge consists of the following components:

2.1. Ready-assembled milk receiver, pieces	1
2.2. Ready-assembled drum, pieces	1
2.3. Ready-assembled case with an mechanical drive, pieces	1
2.4. Float bowl, pieces	1
2.5. Float, pieces	1
2.6. Cream receiver, pieces	1
2.7. Skim milk receiver, pieces	1
2.8. Tap, pieces	1
2.9. Passport, pieces	1
2.10. Shipping case, pieces	1
2.11. Spare parts and implements:	
a) rubber ring (for drum sealing), pieces	1
b) special wrench, pieces	1
c) plastic case, pieces	1
d) separating plate, pieces	1
e) screw 4x40, pieces	3
f) nut Ø4, pieces	3
g) handle, pieces	1

### **3. STRUCTURE AND PRINCIPLE OF OPERATION**

3.1. The centrifuge consists of case with mechanical drive, drum, skim milk receiver, cream receiver, float, float bowl, milk receiver, and tap.

3.2. The following parts are installed in the case.

3.3. Mechanical drive is turning the drum. For reach the right work of separator please turn the handle with speed of 1 circle/second

3.4. The principal driven element is the drum (fig. 2). Separation of milk into cream and skim milk takes place inside the drum under centrifugal force. The drum consists of plate holder 1 with a set of aluminum plates 3, separating plate 4 with adjusting screw 7, lid 2, seal ring 5, nut 6.

3.5. The delivery, hereinafter “the dishware”, serves for warmed-up milk supply into the drum, and for cream and skim milk withdrawal out of the drum.

The dishware (fig. 1) consists of the milk receiver with a tap, a float bowl, a float, cream and skim milk receivers.

Fig. 1

0596200000-00-27

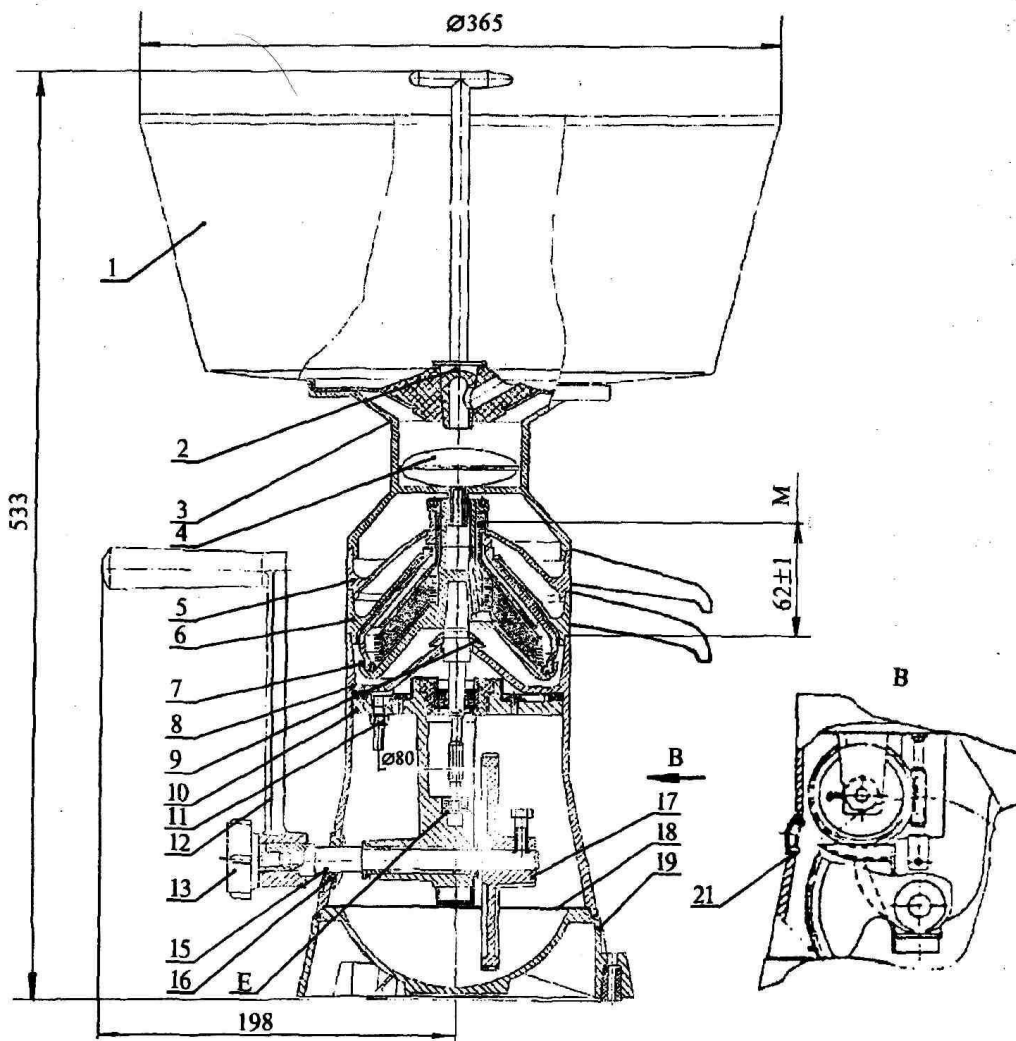

1 - milk receiver ; 2 - cork ; 3 - float chamber ; 4 - float ; 5 - cream outlet ; 6 - skim milk outlet ; 7 - drum ; 8 - body ; 9 - reflector ; 10 - multiplier ; 11 - nut ; 12 - handle ; 13 - screw ; 15 shaft ; 16 - bushing ; 17 - teeth wheel ; 18 - washer ; 19 - base ; 21 - cork

#### 4. SAFETY MEASURES

**Attention!** Before putting the centrifuge into operation please, familiarize with the text of the passport carefully.

4.1. Please flood the mechanical oil into the special hole in the body before using.

4.2. In case of foreign sounds or increased vibration in the centrifuge the operation shall be discontinued, and the failure cause shall be removed.

**Note.** Insignificant trembling of dishware of the centrifuge shall be considered normal in case of operation without milk in the bowl of milk receiver, i.e. at the end of separation.

4.3. It is prohibited to operate the centrifuge with a loose nut of the drum, position 6 (fig. 2).

4.4. It is prohibited to disassemble the centrifuge before the full stop of the drum.

4.7. It is prohibited to open the milk supply tap until the drum reaches its full rotation frequency (in 30...40 seconds after the start).

**Fig. 2**

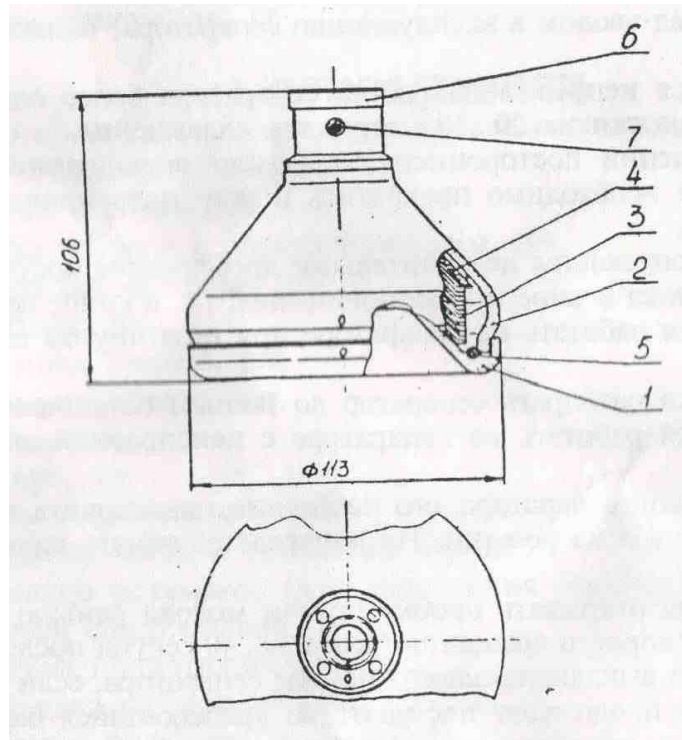

*1 – plate holder, 2- lid, 3 – plate, 4 – separating plate, 5 – seal ring, 6 – nut, 7 – adjusting screw.*

**Fig. 2**

## 5. PRE-STARTING PROCEDURES

5.1. The room where the centrifuge will be installed shall be dry and not dusty with air humidity of  $65\pm 15\%$ .

5.2. The installation area shall be horizontal and level. It is recommended to fasten the centrifuge with three enclosed screws with washers through the holes in the foot.

5.3 Please flood the oil into the special whole in the separator before starting

**Note.** All service and repair operations, such as replacement of electric motor brushes, its disassembly and assembly, cord replacement, shall be carried out by the specialists of the domestic appliances repair shop.

## 6. STARTING

6.1. Before starting, adhere to the following assembly sequence: mount the assembled drum onto the tapered part of the shaft, slightly pressing it with a hand from above (fig. 1).

6.2. Install the skim milk receiver, the cream receiver. Pay attention to the accuracy of their installation at the case and between each other.

6.3. Mount the handle on the housing of separator and fasten it by special screw.

6.4. Turn the handle a little (no more than one round) from be sure that drum doesn't contact receiver

6.5. Position the beaks of skim milk and cream receivers conveniently, set a larger pot for skim milk and a smaller pot for cream.

**Attention!** The tap at the milk receiver shall be in the closed position, i.e. the sharp part of the tap handle shall be turned away from the cut at the edge of milk receiver.

6.6.\* Mount the case of body of the float bowl, put the float inside the bowl, install the milk receiver, set the plastic tap into the taper hole of the plastic case at the bottom of the milk receiver.

6.7. Pour about 130-150 cubic cm (8-9 cubic inch) of machine oil inside the special whole. This whole is situated on the body of separator under the white cork.

6.8. The work speed of separator is 50-60 handle rounds per minute (not more than 70 rounds)

## 7. SKIMMING

7.1. Pour filtered whole milk into the bowl of milk receiver. For the highest efficiency separate milk immediately after milking or warmed-up to the temperature of  $35\dots 40\text{ }^{\circ}\text{C}$ .

7.2. Start to turn the handle of separator. After the drum reaches its full rotation speed, in 1 circle of handle per 1 second, open the tap, i.e. turn the tap handle (its sharp part) towards the cut at the edge of milk receiver.

7.3. Having completed skimming, pour about 3 liters of warm water into the bowl for milk in order to wash the centrifuge and let it pass through the running centrifuge to remove skim milk and cream remains.

7.5. To stop the centrifuge turn the tap left or right from the cut at the edge of milk receiver, wait until the rest of cream and skim milk runs out, and only after that unplug the electric drive with the help of the switch.

## 8. PRE-WASHING DRUM DISASSEMBLY PROCEDURE

8.1. The drum is disassembled with the help of the special wrench available in the accessories kit (fig. 3). Unscrew the nut. The drum lid normally sits tightly on the plate holder,

therefore you need to turn over the drum and hit the face of the threaded part on a wood board in the direction of an arrow.

It is prohibited to hit the threaded face of the drum on the hard stand.

8.2. On opening the drum dismount the separating plate, then dismount the set of plates, the seal ring.

**Note.** When disassembling the drum do not affect the regulation of cream fat content (richness), i.e. do not unscrew the adjustment screw in the upper part of the separating plate without necessity. Take care of the seal ring integrity.

**Attention!** It is prohibited to disassemble the drum with outstanding adjustment screw (fig. 2).

8.3.\* Two types of plates are installed by turns in the drum: marked “A” – 5...6 pieces, marked “B” – 5...6 pieces. At first the plate marked “A” is mounted on the plate holder, then the plate marked “B”, and so on.

**Attention!** After every two milk fillings and skimming (about 20-25 liters) the centrifuge shall be disassembled, and all the components of the drum shall be washed. When assembling the drum it is recommended to grease the nut with any edible fat.

\*Instead of “A” mark at the bottom flange of the plate there may be punched one dot, instead of “B” mark there may be two dots. In this case at first the plate with one dot is mounted on the plate holder, then the plate with two dots, and so on.

## 9. DRUM ASSEMBLY

9.1. The assembly is carried out in reverse order of the drum disassembly, i.e. put the rubber ring into the slot, mount aluminum plates sequentially, do not apply extra force, because with an easy turning the plate is mounted on the trihedron of the plate holder in the required position. The set of plates shall be complete (the number is indicated in the passport).

9.2. Cover the set of plates with the separating plate in such a way that its jut would enter the slot at the drum lid.

9.3. Superpose “0” mark at the drum lid with such a mark at the bottom of the plate holder (fig. 2).

9.4. Screw the nut with a hand. Final tightening of the nut shall be executed with a special wrench by inserting two jets of the wrench into two holes of the nut. Tighten the nut until “0” mark on the nut is superposed with the hairline (cut) at the threaded part of the plate holder (fig. 2), (fig. 3).

**Attention!** Do not overtighten the nut, and do not forget to tighten the nut, otherwise the drum will become depressurized at operational speed.

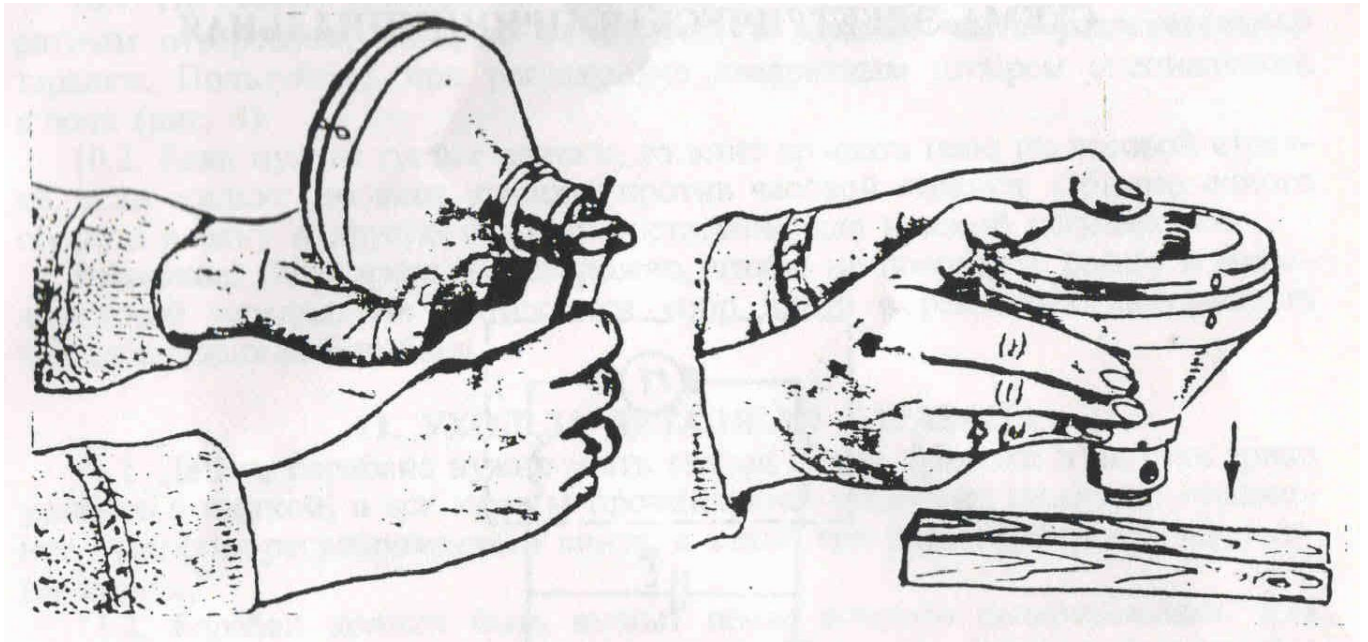

**Drum dismantling**  
**Fig. 3**

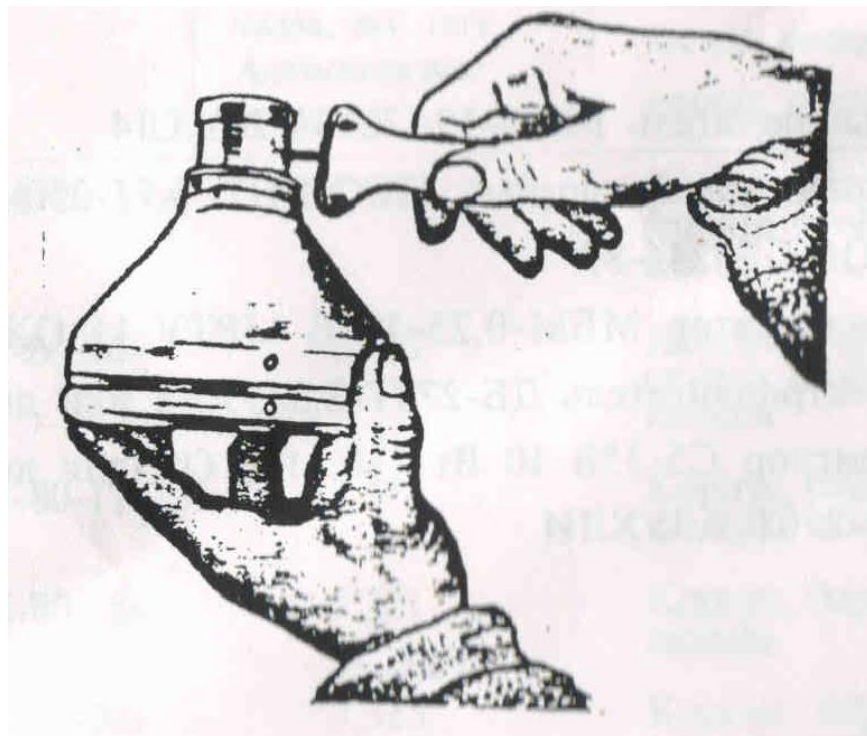

**Fat content regulation**  
**Fig. 4**



## **10. REGULATION OF CREAM FAT CONTENT**

10.1. At your discretion adjust the cream richness by a screw with square hole located at the upper part of the separating plate. When adjusting the screw use the square pin of the special wrench (fig. 4).

10.2. If you need to get rich cream, you should turn the screw clockwise, if you need to get watery cream, you should turn the screw counterclockwise. One turn in either direction is usually enough for required adjustment.

**Attention!** The screw shall be turned carefully, to avoid overturning the thread in the separating plate. The screw stop on the threaded surface of the drum plate holder shall be excluded.

## **11. DRUM COMPONENTS MAINTENANCE**

11.1. Drum components shall be washed with warm water. Milk and dirt remains are removed with a brush, and all the valves are cleansed with a barbed nail especially the square hole of the adjustment screw, as well as three oblique holes of the plate holder.

11.2. The drum shall be washed after each skimming. Acids and alkalis shall not be used for cleansing, because aluminum parts will become blotted and may rupture.

11.3. The maintenance of other parts of the centrifuge is similar to that of the drum components. After washing the components shall be wiped dry with a clean dish-cloth.

## **14. MANUFACTURER'S WARRANTY**

14.1. Manufacturer guarantees normal operation of Milk Skimming Centrifuge within 12 months of the date of retail sale or, if not specified, of the date of manufacture.

14.2. If any malfunction through Manufacturer's fault is detected during the warranty period, the owner has a right for maintenance or replacement of the centrifuge free of charge. Maintenance shall be carried out at either manufacturing plant, or warranty repair shop provided that the warranty service coupon is presented.

14.3. Manufacturer guarantees safe operation during the whole warranty period provided the consumer fulfills the requirements as specified in sections 4 and 5.

**Purchase date:**