

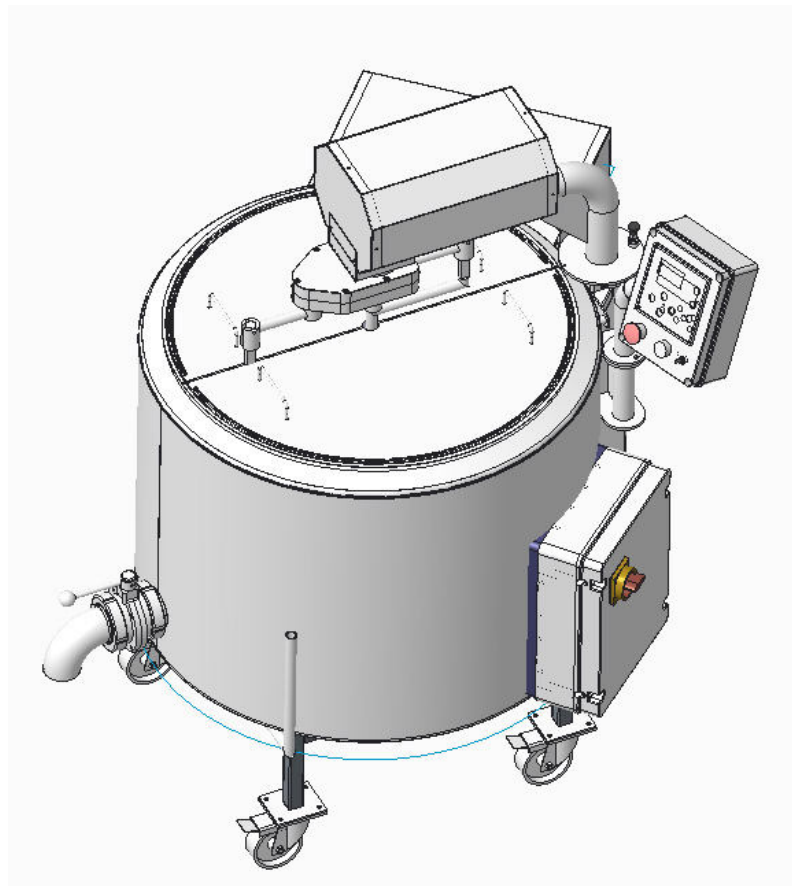

JANSCHITZ

GMBH

Multi function kettle - closed type FJ - 200 CT



Janschitz G.m.b.H
Eisenstrasse 81
A – 9330 Althofen

Tel: +43 (0) 4262 22 51-0
Fax: +43 (0) 4262 22 51-23
www.janschitz-gmbh.at
office@janschitz-gmbh.at

TABLE OF CONTENTS

TABLE OF CONTENTS	1
1. GENERAL SAFETY RECOMMENDATIONS	2
2. TECHNICAL SPECIFICATIONS	4
3. UNPACKING	5
Accessories	5
4. DEVICE SETUP	5
Main components	5
Electrical connection	9
Water connection	9
Water filling into secondary coat	9
Filling procedure:	10
Water quality	11
5. PROGRAM SETUP	12
Control panel	12
Main menu	14
Settings menu	14
Detailed menu	16
Heating procedure	18
Cooling procedure	18
6. CLEANING	19
Detergents	19
7. MAINTENANCE AND SERVICE	20
Troubleshooting	20
Electric case contents	21
Advanced settings menu	22
8. DEVICE ASSEMBY AND SPARE PARTS	23
Device spare parts list	27
Spare parts ordering procedure	27
9. WARRANTY	28

1. GENERAL SAFETY RECOMMENDATIONS

- **Before any installation read this manual very carefully.**
- **When using this device follow instructions in this manual and instructions for safe work.**
 - **When working always wear tight clothes, do not wear a tie.**
 - **Protect long hair with suitable head protection.**
 - **Do not wear jewelery (rings, necklace, etc.).**
 - **Wear eye protection – protective glasses.**
 - **Be at full psychophysical abilities when using this device.**
 - **Illuminate the working area according to regulations.**
 - **Assure the clean and tidy working place, surrounding of the device should be free.**
- **Connect the device to a proper electrical socket.**
- **Only trained personnel is allowed to use this device.**
- **Before turning on the device always check:**
 - **That no part of the device is damaged.**
 - **That moving paths are clear of obstructions.**
 - **That device is FILLED WITH WATER**
- **The device has to be switched on by main switch.**

- **When there is a defect on the device, you must turn it off and put the plug from the power source.**
- **Don't repair the device by yourself, in case of malfunction rather call authorized service provided by your distributor. Only authorized service with faultless tools can repair the device.**
- **Always report every breakdown or defect on device.**
- **In case of serious malfunctions switch off the main switch and unplug the device from electrical socket and compressed air socket, then call authorized service.**
- **You are allowed to use only the procedures that are described in this manual. Use of any other procedures or adjustments could result in destruction of the device or injury. Injuries connected with such procedures can not be subject of any product liability claims.**
 - **Do not reach into danger area – moving parts!**
 - **Do not leave the working area when device is in operation!**
 - **Do not lean the device while in operation!**
 - **Do not remove warning labels or security devices. Blocking or removing the security devices is forbidden!**

- **It is forbidden to clean, lubricate or repair the device during operation.**
- **Disconnect device from electrical socket before cleaning!**
- **Take care that milk, water or humidity will not come into the device.**



BEFORE FIRST INSTALATION, CONNECT THE HOUSING OF THE DEVICE TO A PROPER EARTH CONNECTION TO AVOID INJURIES AND DAMAGE.

CAUTION:

AT NORMAL OPERATION HEATER PARTS COULD WARM UP. RISK OF BURNING IS POSSIBLE, AVOID CONTACT WITH HOT SURFACES.

CAUTION:

HOT - RISK OF INJURY.



WARNING!

Only trained people who are familiar with rules for safe work are allowed to work with this device.

NEVER START THE DEVICE BEFORE FILLING WATER, OTHERWISE HEATING ELEMENTS WILL BE DESTROYED AND INJURIES MAY ACCUR.

We are glad that you decide to buy our device and we promise that it will serve you for a long time if you will use and clean it according to descriptions stated in this User`s manual.

2. TECHNICAL SPECIFICATIONS

PRODUCT		FJ - 200 CT 400 V
Operating voltage	[V/Hz]	400 / 50
Power supply		3 phase (3x230V), 18A
Type of heating	[W]	electrical
Heater power	[W]	15.000
Current	[A]	22
Max. capacity	[litres]	200
Minimum capacity	[litres]	40
Volume of heating water	[litres]	15
Dimension of Milk outlet	DN	65
Dimension of cold water inlet (cooling)	[mm]	DN20
Dimension of hot water outlet (cooling)	[mm]	DN20
Dimension of external water inlet (heating)	[mm]	DN20
Dimension of external water outlet (heating)	[mm]	DN20
Maximum temperature	[°C]	100
Dimensions in cm	(w x d x h)	130x120x150
Net weight	[kg]	185
Protection type of electrical box		IP 56

CAUTION!

Minimum voltage applied is 220V, maximum voltage is 250V!

FJ-200 CT multipurpose kettle is designed for thermal processing of milk into dairy products (pasteurized milk, crème, cheese, yogurt, ...). Multipurpose kettle has closed type construction, so heating water is always under pressure. For cooling, tap water or cooling tank water is used. Cooling water flows freely through plate heat exchanger when cooling is applied. For heating one can choose from different modes of heating:

- **Electrical heating.** Two electrical heaters with 6 kW power are installed and only heaters are used for heating.
- **External heating.** The kettle has two connections for external water (External water in and external water out). When outer heating room has enough capacity and adequate temperature it can be used for heating when connected to the kettle. In this mode only external water is used for heating.
- **External + Electrical heating.** In this mode external water is used to heat up the milk to preentered temperature. When this temperature is reached, external water heating is stopped and only electrical heaters are used to heat milk above preentered temperature.

It is easy to use product.

3. UNPACKING

Unpack the device carefully and check that nothing is left in the cardboard box. Place it on the plain and stable floor in clean, dry and dust-free place. Before use check that all parts are assembled according to instructions.

Room temperature where device is placed must never fall under 10°C, also it is not recommended that room temperature exceeds 30 °C. With low room temperature, the maximum milk temperature decreases.

Accessories

Packaging of multi purpose kettle contains the following accessories:

- 200 liter multi purpose kettle
- Two half covers with handles
- Outlet valve DN65 with outlet elbow
- Option 1 (Stirrer and stirring guide)
- Option 2 (3 part cheese harp, central stirrer and stirring guide)
- User's Manual

Please note!

Main cord must be connected to safety outlet with grounded terminal!

4. DEVICE SETUP

Main components

All important parts of device are named and described below:

1. The kettle
2. Milk outlet valve with knee outlet
3. Two part cover with handles
4. Electric case
5. Controlling cabinet
6. Microprocessor unit
7. Power cord and socket (non European editions come without a socket)
8. Tilting lever (mechanism to lean the kettle when empty)
9. Stable support with wheels
10. Motor cover
11. Rotating motor support
12. Heating unit cover
13. Rotating control box support
14. ON/OFF switch
15. Fixing device for motor support
16. Milk temperature sensor (two temperature probes)
17. Electro heaters

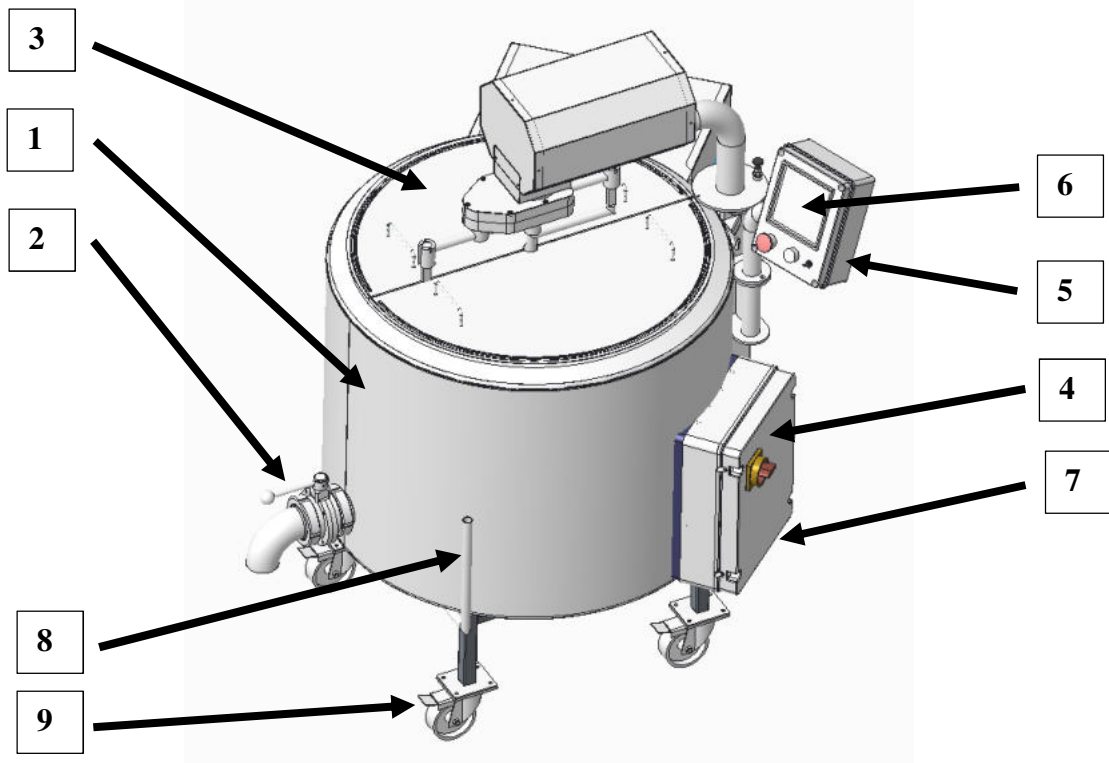

Picture 1

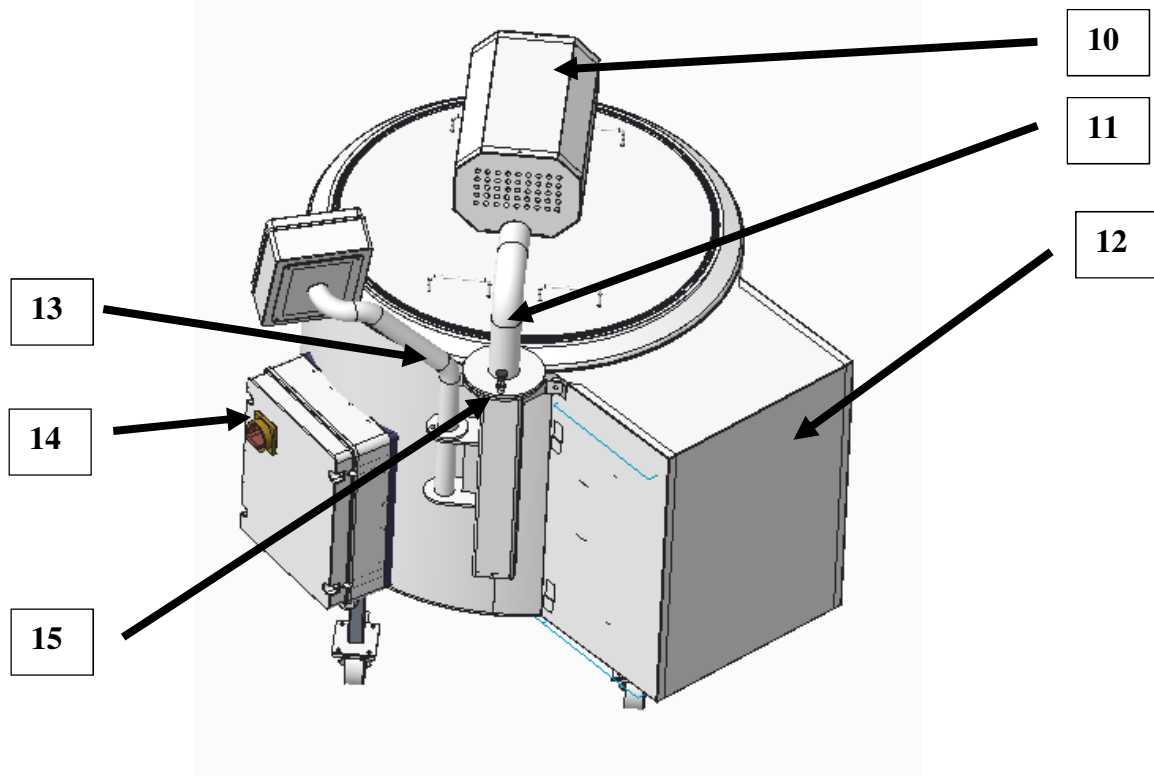

Picture 2

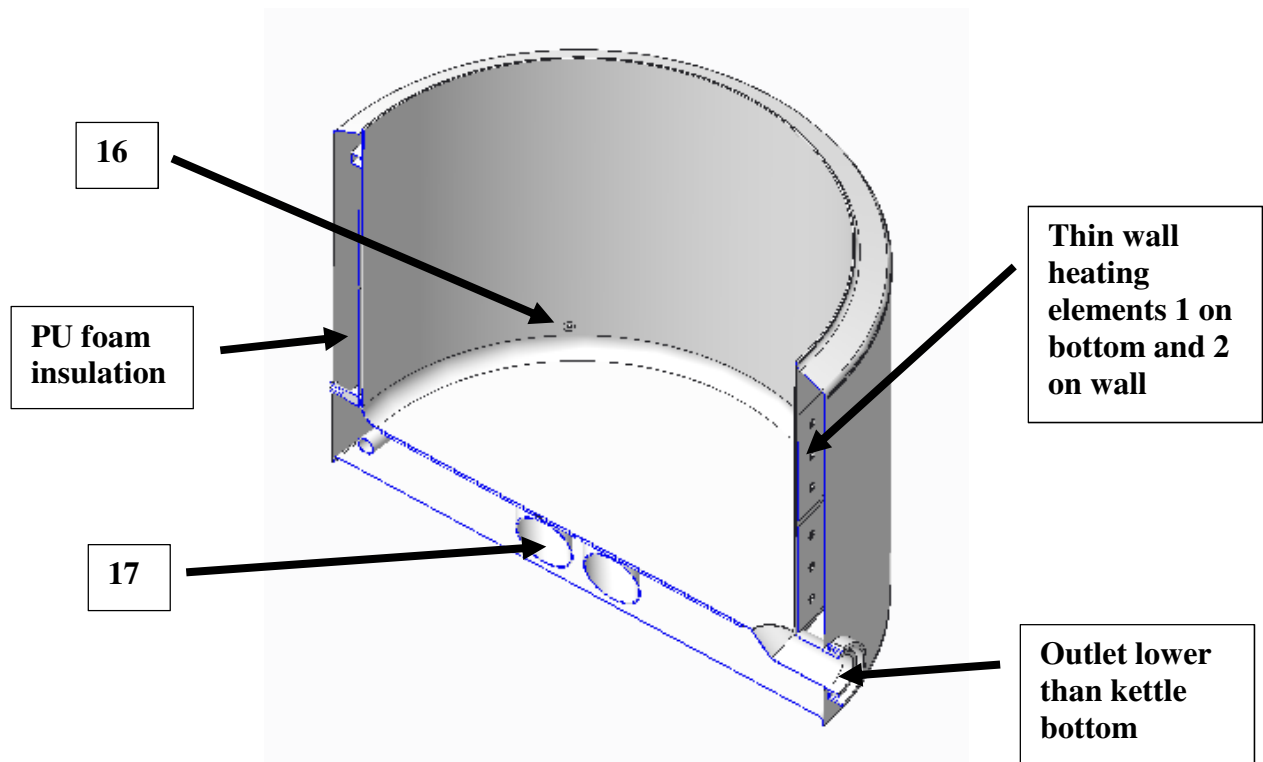

Picture 3

All important parts of heating unit are named and described below:

1. Venting device
2. Expansion vessel
3. Circulating pump
4. Manometer
5. Safety valve for overpressure
6. Manual valve for disconnecting the upper heating element
7. Electronic manometer
8. Plate heat exchanger for cooling water
9. Motor valve for external heating
10. Mixing valve for external heating
11. Solenoid valve for cooling water

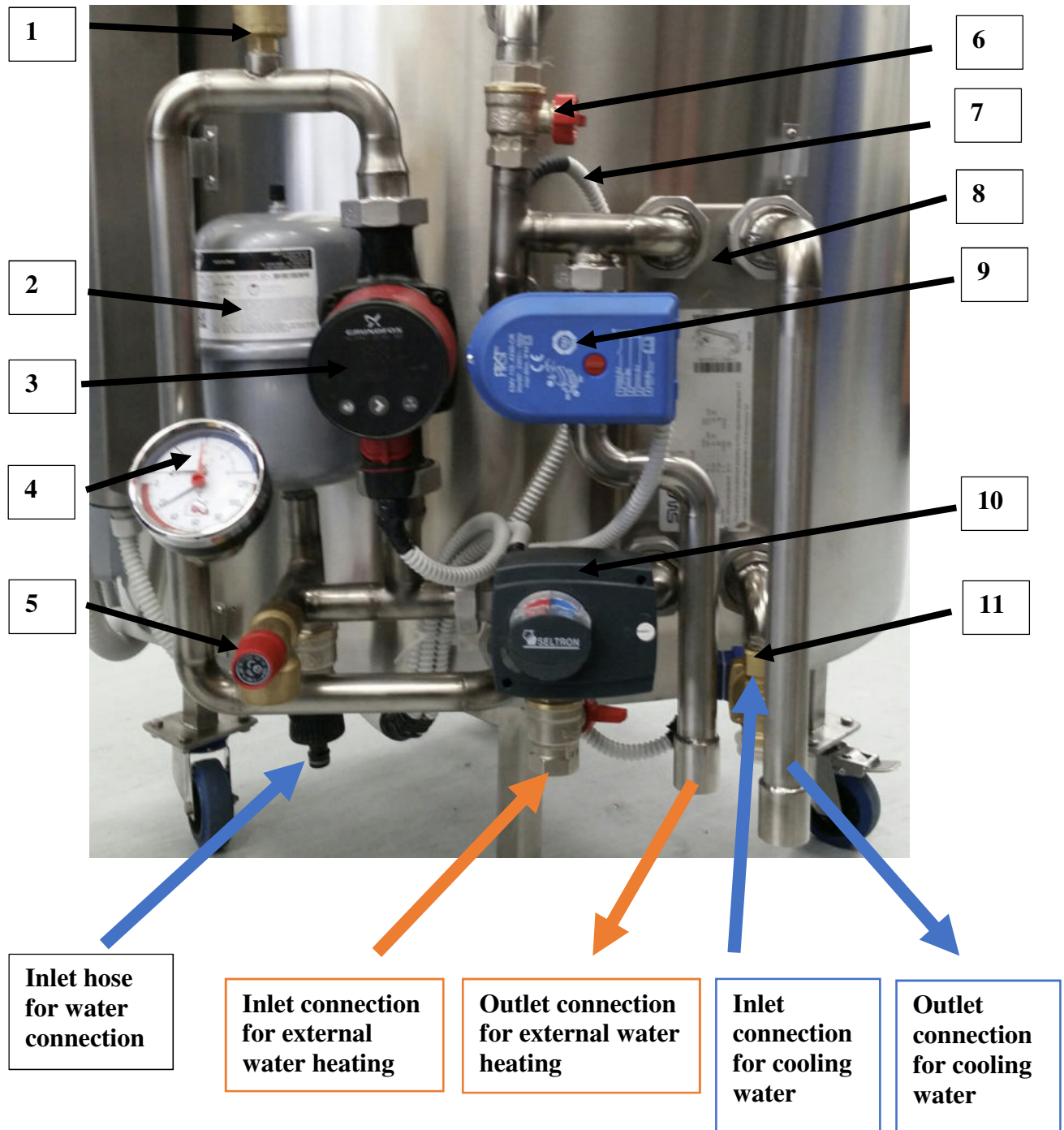

Picture 4

Electrical connection

Before connection of device on electrical network, make sure that data on name label matches with voltage of power supply. Also connect the kettle housing to the ground – earthing connection.

NOTE: Version for non European market is supplied without electrical socket! Only trained personnel may connect proper locally approved multi phase socket to supplied device (see electrical scheme).

Water connection

Before each start of device, make sure that device is filled with water! You can use water from tap that fulfils the microbiological and chemical requirements. Water must be poured in slowly, not more than 3 l/min.

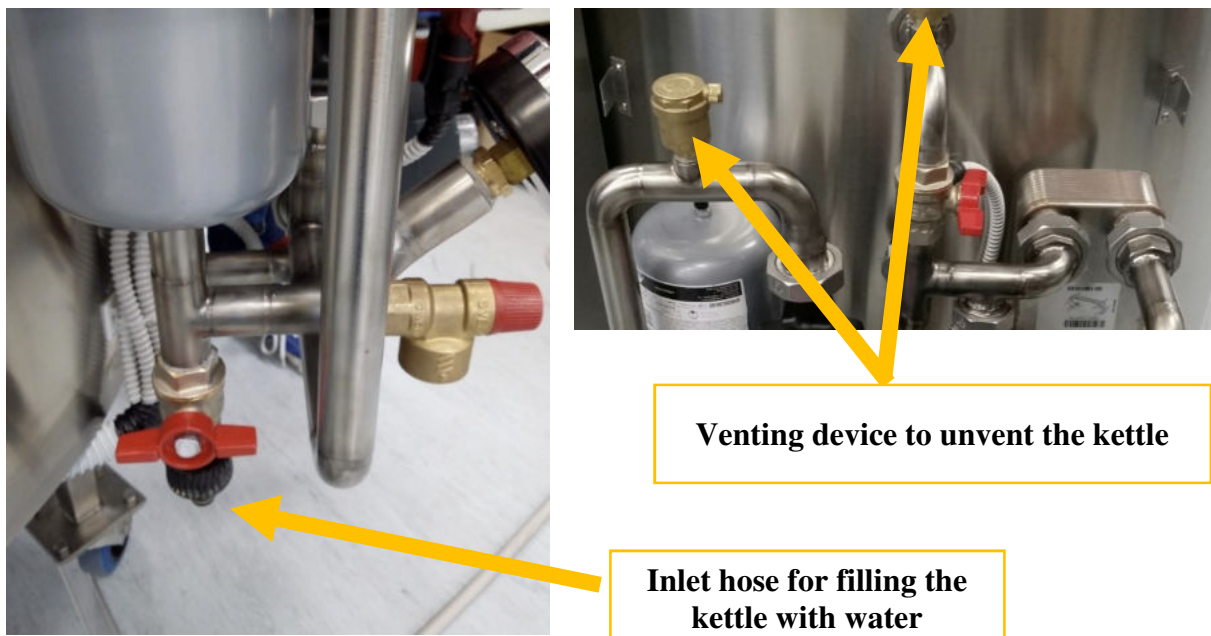

Water filling into secondary coat

Use inlet hose to fill water into the double layer of kettle. The device needs to be properly filled with secondary water before start. Lack of secondary water or use of inappropriate water can damage the device. At startup program first checks for the presence of secondary water and demands the filling if no or inappropriate pressure of secondary water is detected.

Filling procedure:

- Connect the tap water connection to inlet hose
- Open the venting devices to let the air out
- Choose to fill water at microcontroller and wait 2 minutes.

When electronics is energized it first checks if heating water is present.

It offers to fill the water by pressing up key



or skip the choice by pressing down key.



Menu with water filling choice will disappear in 5 seconds after start.

If no pressure is present it will not allow to proceed.

When you choose to fill water, manually connect the water supply to the device. You must wait 2 minutes for the mixing valve to change position before filling.

Slowly open the manual valve to **slowly fill the water into the device**. After correct pressure is formed **1,5 bar**, close the manual valve and remove the water supply from the device.

Manually start the pump by electronics by



pressing left key to enter the settings menu and to go to line "Circulat. Pump:".



With key change the value from "AUTO" to "ON" .

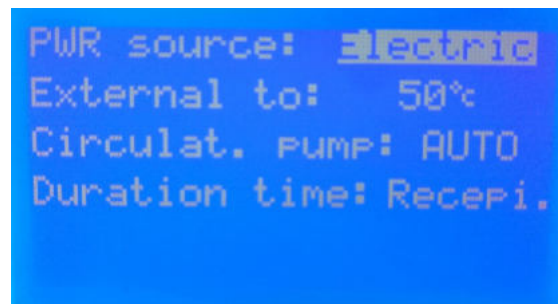
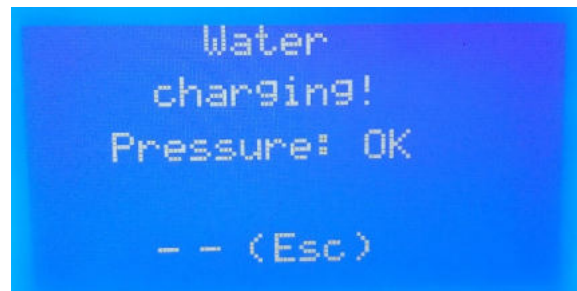
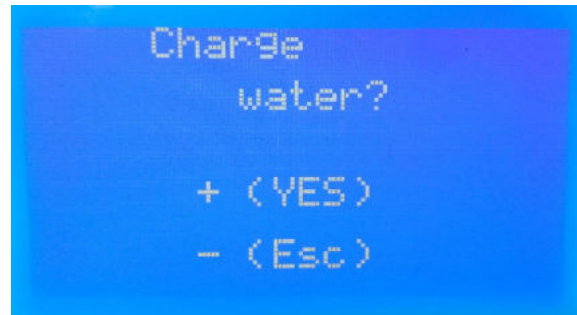

- Pump must circulate the water for so long that venting devices put all the air out of system. Pressure may fall during this procedure, so more water must be added by opening the valve at inlet hose to maintain the optimal pressure **1,5 bar**.
- When kettle is vented, close the valve at inlet hose and remove the water connection and stop the circulating pump.

To change mode for circulation pump, press



left key to enter the settings menu.
Go to line “Circulat. Pump:” and then change the value to “AUTO” by pressing down key.

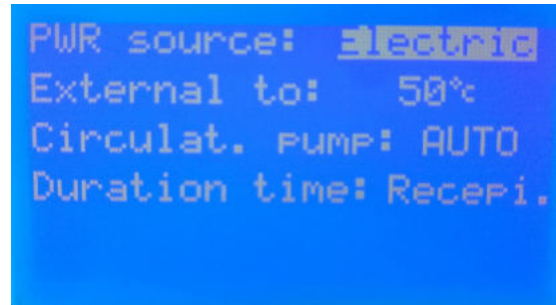

- With kettle properly vented you will have 1,5 bar pressure inside the kettle. During operation you will have to check the water pressure regularly and add water if pressure drops.

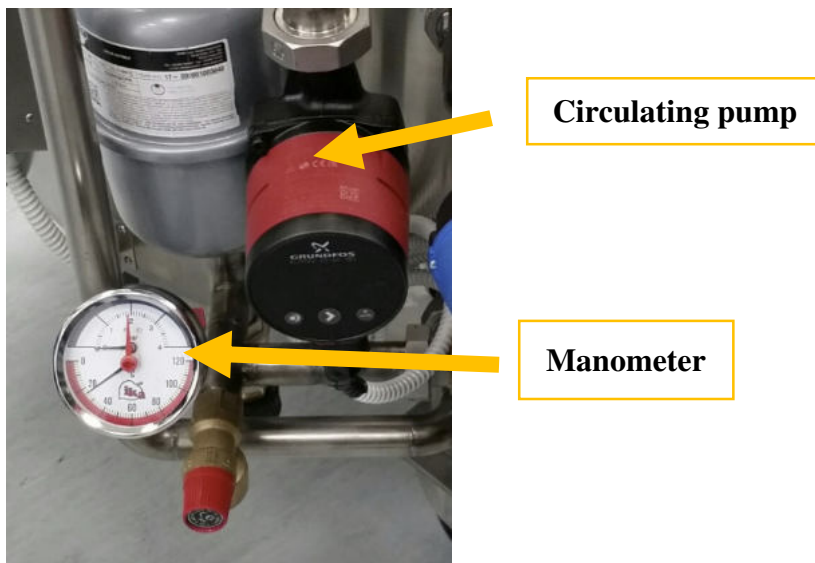

Circulating pump

Manometer

Water quality

The quality of the water used for washing, rinsing, heating, cooling is very important. The water used must be appropriate for drinking. This requirements must be fulfilled to prevent accumulation of bacteria on equipment surfaces. It is also important to prevent accumulation of lime scale and to prevent corrosion on surfaces inside the device. Water must be clean both microbiologically and chemically.

Microbiological requirements for water

All coliform bacteria	Absent in 100ml
Faecal coliform bacteria	Absent in 100ml
Faecal streptococci	Absent in 100ml
Spores of sulfide reducing clostridium	Absent in 100ml
Microflora standard (PCA) at 22°C	Less than 100 CFU in 1ml
Microflora standard (PCA) at 37°C	Less than 100 CFU in 1ml
Pathogenic microorganisms	Absent
Iron oxidizing bacteria	Absent

In the case of chlorination of non-potable water residues that could affect the quality of the product or corrosion on the installations are not allowed.

Chemical characteristics of water

- Ammonia, hydrochloric acid, sulfuric acid, hydrogen sulfide and hydrofluoric acid must be absent from the water.
- The amount of iron can be 0.2 to 0.3 mg / l. The water must not taste of iron.
- Lead must be absent.
- Water should be free of alkaline earth metal salt. This will facilitate the cleaning and disinfection and improve the transmission of energy and reduce plaque on surfaces.
- The content of chloride ions must be less than 50 ppm.

WARNING!

Hardness of water, water should be soft (4-8 °dH)

Base, acid scale of water, pH value should be neutral pH 7 (+/- 1)

Water must comply with standards DIN 2000 and DIN 1988.

Inappropriate water (inside the device) directly affects the life expectancy of the device which could be shortened by half. Water should be neutralized (with use of filter, softening devices, etc.) for longer life of the device.

5. PROGRAM SETUP

Control panel

Control panel of micro controller unit has four buttons (see picture below).

- With pressing on a green button you start a process.
- With pressing on a red button you stop a process.
- With pressing MIX button you start rotating a stirrer or you stop rotating a stirrer if it is already rotating.
- With four buttons (up, down, left, right) you manipulate process data and settings. With keys up and down you can change entered values.

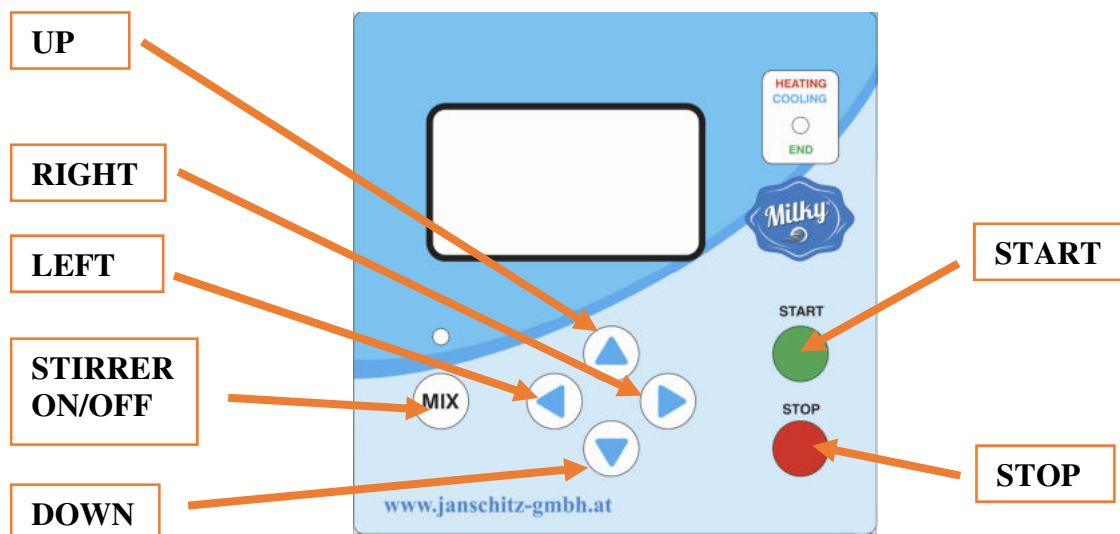

When device is energized you can read most important values on the screen.



Before start of the heating process make sure the device is properly filled with water and that settings are properly adjusted.

Control panel of micro controller unit has also indicating led lights.

- ORANGE light above “MIX” button indicates that stirring is activated and mixer or harp system rotates.
- GREEN BLINKING light on the upper right corner indicates that process is done.
- RED light on the upper right corner indicates that process of heating is currently active.
- BLUE light on the upper right corner indicates that process of heating is currently active.

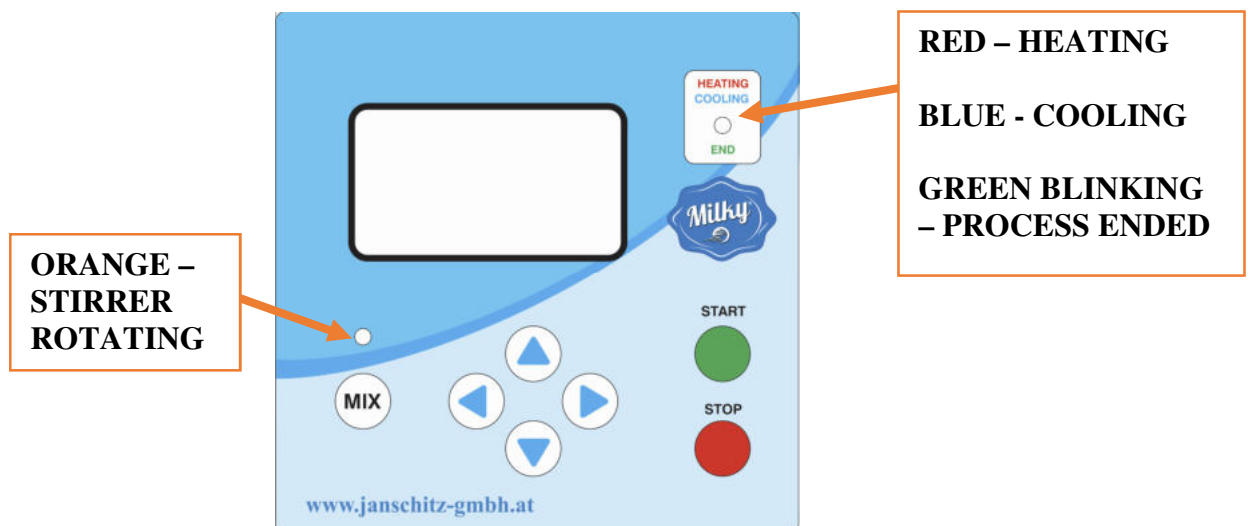

Main menu

The control panel of microprocessor unit is clear and easy to use. If no button is pressed it will show main menu with all necessary data.

On the left side of control panel process setpoints are displayed when process is running, otherwise only current clock is shown.



On the right side of control panel, milk temperature is displayed in large font. Below is information about the stirrer and process state (heating, cooling)

There is also an icon displayed for each heater and cooling valve when activated.

When the process is running on left side is information about current phase (1-4), Setpoint temperature and duration time (elapsed time – set time)



Settings menu

The settings menu is entered when right key  is pressed in main menu configuration. First page of settings menu is a setpoint table of temperatures [°C] and times [min].

With pressing up key, value is increased by 1 unit.



With pressing down key, value is decreased by 1 unit.



With pressing right key, you switch to another item.



Settings recepies...

Pha.	1	2	3	4
°C	95	65	90	40
m	30	30	30	30

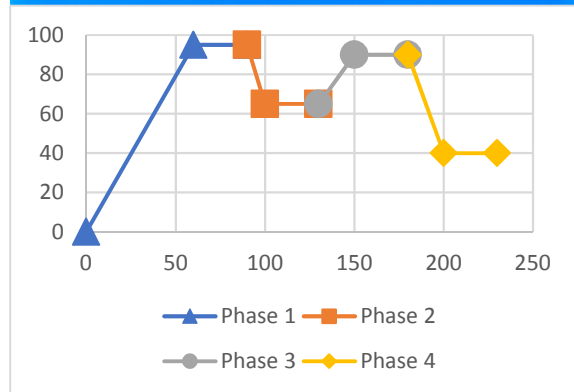

Second page of settings menu offers:

- **Reduction of heating power** from 10-100 % with increments by 10 %

To decrease, press  key, to

increase, press  key.

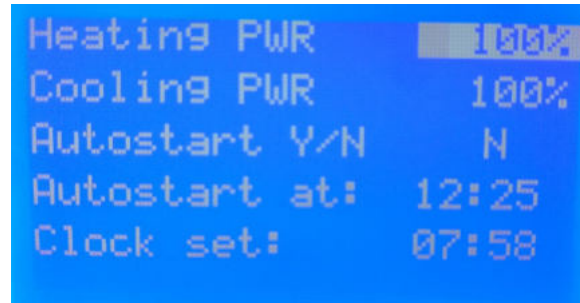

- **Reduction of cooling power** from 10-100 % with increments by 10 %

To decrease, press  key, to

increase, press  key.

- **Option for autostart the process** with entered setpoint table. To

autostart select “Y” with  key.

Clock can be set in this page of settings, values can be changed by pressing up key for increment and down key for decrease. Third page of settings menu offers power settings.

Power source can be set:

- **Electric** (only electric heaters are used for heating)
- **External + electric** (External water source is used to heat up milk to a set temperature, above that temperature external water source is closed and only electro heaters are used for heating)
- **External** (Only external water source is used to heat up milk)

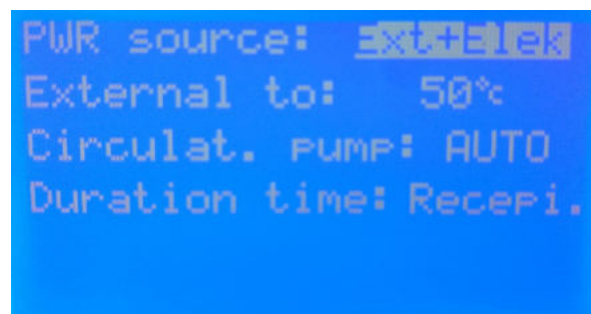

Switch temperature of milk at which switch between external power source and electrical power source is made. (when External+electric is used)

Circulation pump can be manually

switched on with pressing  key.

Normal setting for circulation pump is "AUTO".

Duration time setting is factory made "**Recipe**". That means when milk reaches setpoint temperature, it then holds at this temperature for a set amount of time, before it proceeds to the next phase.

If duration time is set as "**Manual**", device will hold at setpoint temperature for infinite amount of time. Only with pressing the

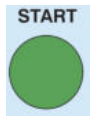

key it switches to next phase.

Detailed menu

The detailed menu is entered when up key  is pressed in main menu configuration.

In first page of detailed menu on the left side:

- Milk temperature is shown
- Secondary water temperature is shown
- Return water temperature is shown
- Pressure state of secondary water is displayed
- Input sensor states are displayed in binary form
- Output sensor states are displayed in binary form

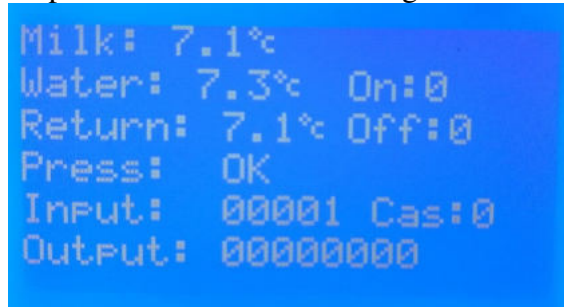

```

Milk: 7.1°
Water: 7.3° On:0
Return: 7.1° Off:0
Press: OK
Input: 00001 Cas:0
Output: 00000000
  
```

Input sensors in binary form:

- Digit 1- level sensor
- Digit 2-
- Digit 3-
- Digit 4-
- Digit 5-

Output sensors in binary form:

- Digit 1- Heater 1
- Digit 2- Heater 2
- Digit 3- Circulation pump
- Digit 4- Cooling solenoid valve
- Digit 5- Mixing valve open (external source)

Digit 6- Mixing valve close (external source)

Digit 7-

Digit 8- Motor valve open (external source)

On the right side process control parameters are calculated.

- On represents temperature of water when command is activated
- Off represents temperature of water when command is deactivated
- Cas represents the inclination of heating curve (for fast or slow process characterization)

Second page of detailed menu shows simplified state of main device components.

When component is active the value is 1, if component is deactivated, value is "0"

```

Heater 1: 0
Heater 2: 0
Pump:      0
Cooling    0
MU open:   0   Ext.v:0
MU close:  0   Mix:  0
  
```

Third page of detailed menu shows calculated parameters.

Heating difference value represents the maximal heating difference between milk and secondary water.

Cooling difference value represents the maximal cooling difference between milk and secondary water.

Actual difference between milk and secondary water is calculated.

Analog value of Milk sensor is shown.

Analog value of Water sensor is shown.

Analog value of Return water sensor is shown.

```

Heating dif.: 24.0%
Cooling dif.: 24.0%
Dif milk-water: 0.0%
AdMilk: 4323
AdWater: 4325
AdReturn: 4323
  
```

Heating procedure

Before heating procedure device must be properly connected.

- Place the device on the firm, plain and stable floor. It is recommended that the source of cooling water and the drain is not more than 2 m away from the device.
- Connect water supply to inlet hose and start filling procedure explained in chapter 3
- Connect power supply to electric case.
- Pour desired amount of milk into the kettle.
- Turn on the device – Turn the main switch on (located on the side of the electric case).
- Heating can begin when device is properly setup (see chapter 6).
- Press green button to start the heating process. The red light on the upper left part of control box is lit, indicating the heating is in progress. The display shows the present temperature and begins to heat till setpoint temperature is reached.
- After set temperature is reached heating transforms to holding, control unit beeps and the holding time is displayed on screen.
- Device switches to next phase automatically when holding time is passed and stops the process automatically when fourth phase holding time is passed.
- You can switch the phases if you want, by pressing the start key.

Cover the kettle with two part lid. If kettle is not covered with lid, the time of heating will be longer and it will not reach maximal stated temperature!

If you want to move on second process, even if first process is not finished yet, just press key start.

Cooling procedure

Before cooling procedure device must be properly connected. (see chapter 1, 3 and 5).

- Connect cooling water to cooling water inlet connection
- Connect drain hose to cooling water outlet connection.

Slowly open the valve on your water network or cooling tank, that you connected inlet hose to. Cooling water supply must allways be connected to the device, device will open the flow automatically, when needed. When setpoint temperature of milk will be lower than current temperature of milk, the device will automatically start the cooling procedure. The blue light on the upper left part of control box is lit, indicating the cooling is in progress. Cold water will slowly come in the device's plate exchanger and out through outlet hose to the drain or back to cooling tank (differs from your connection). Cooling speed depends on cooling water temperature and flow. When desired temperature is reached, cold water flow will be automatically stopped by solenoid valve.

ATTENTION:

**Cooling water coming out of plate heat exchanger hose is hot!
Be careful that hose for outlet cooling water is free (is not pressed)**

6. CLEANING

Before cleaning make sure that the device is switched off and disconnected from main power supply. Some of device parts could be hot, let them cool down before cleaning.

- The milk kettle and the cover should be cleaned with hot water adding fat soluble detergents. Afterwards these parts should be rinsed with pure water.
- Other equipment shall be cleaned only with wet cloth and afterwards dried with dry cloth.
- Do not use abrasive materials to avoid scratches.
- After use always clean the kettle. Do not use aggressive detergent.
- If milk or cream rests get dry do not remove them with sharp objects or sharp duster.

Detergents

The base and acid for cleaning must meet the specifications of the manufacturer and should not contain foreign content, which would change the effect of the cleaning solution and affect the equipment. The same applies to disinfectants.

- The base detergent which is usually used is sodium hydroxide (NaOH, caustic soda) with concentration 30/36%. Dilute it to a final concentration of 0.2 / 2% at 70 ° C.
- Maximum content of chloride ions in the solution of sodium hydroxide is 50 ppm. The solution should not contain impurities.
- The acid detergent which is normally used is a solution of nitric acid (NOH3) 33/36% concentration. Dilute it to a final concentration of 0.5 / 2% at 65°C.
- Maximum content of chloride ions in the solution of nitric acid is 50 ppm. The solution should not contain impurities.

Ensure that no water comes into contact with electronics and electronic parts.

Please note!

Before cleaning you must always disconnect device from electricity.

Use lift handle to lean the empty kettle for easy cleaning.

7. MAINTENANCE AND SERVICE

Troubleshooting

When a fault occurs, the information will be written on display and device will stop, if not stop it yourself by main switch and disconnect it from main power supply. When device malfunctions, disconnect the device from mains and call the authorised service - do not repair it yourself!

In the chart below are most common errors and resolutions

Error code	Description	Resolution
1	Device will not start, the information on display is: "Water pressure too low"	There is low pressure in heating water system, add water, optimal pressure is 1,5 bar
2	Device will not start, the display is blank	<ol style="list-style-type: none"> 1. Check the main power supply 2. Check the main switch position
3	Device worked, then it suddenly stopped and will not start, the display is blank	<p>Authorized personnel may open electro case and check the fuse state.</p> <p>If the fuse is activated call authorized service to check for electrical malfunctions.</p>
4	Device worked, then it suddenly stopped and will not start, the display is blank	<p>Authorized personnel may open electro case and check the thermostat state (position 5, chapter 7)</p> <p>If the thermostat is activated the device has overheated - call authorized service. The security switch switched off all functions on the device. (overheating protection).</p>
5	Water is flowing through safety valve in heating unit	There is too much pressure in the system, reduce the pressure as safety valve activates at 3 bar, optimal pressure is 1,5 bar.

In the chart below are fault displays, meanings and the resolutions.

Error code	Description	Resolution
1	Water pressure too low	See chapter with water filling
2	Milk Temperature overload	Milk temperature exceeded the setpoint temperature
3	Heating temperature overload	Water temperature exceeded the setpoint temperature
4	Milk temperature probe fault	Milk temperature probe/unit is to be replaced
5	Water in temperature probe fault	Water temperature probe/unit is to be replaced
6	Water out temperature probe fault	Water temperature probe/unit is to be replaced
7	Circulation pump fault	Circulation pump is to be replaced
8	Pressure sensor fault	Electronic manometer is to be replaced

Electric case contents

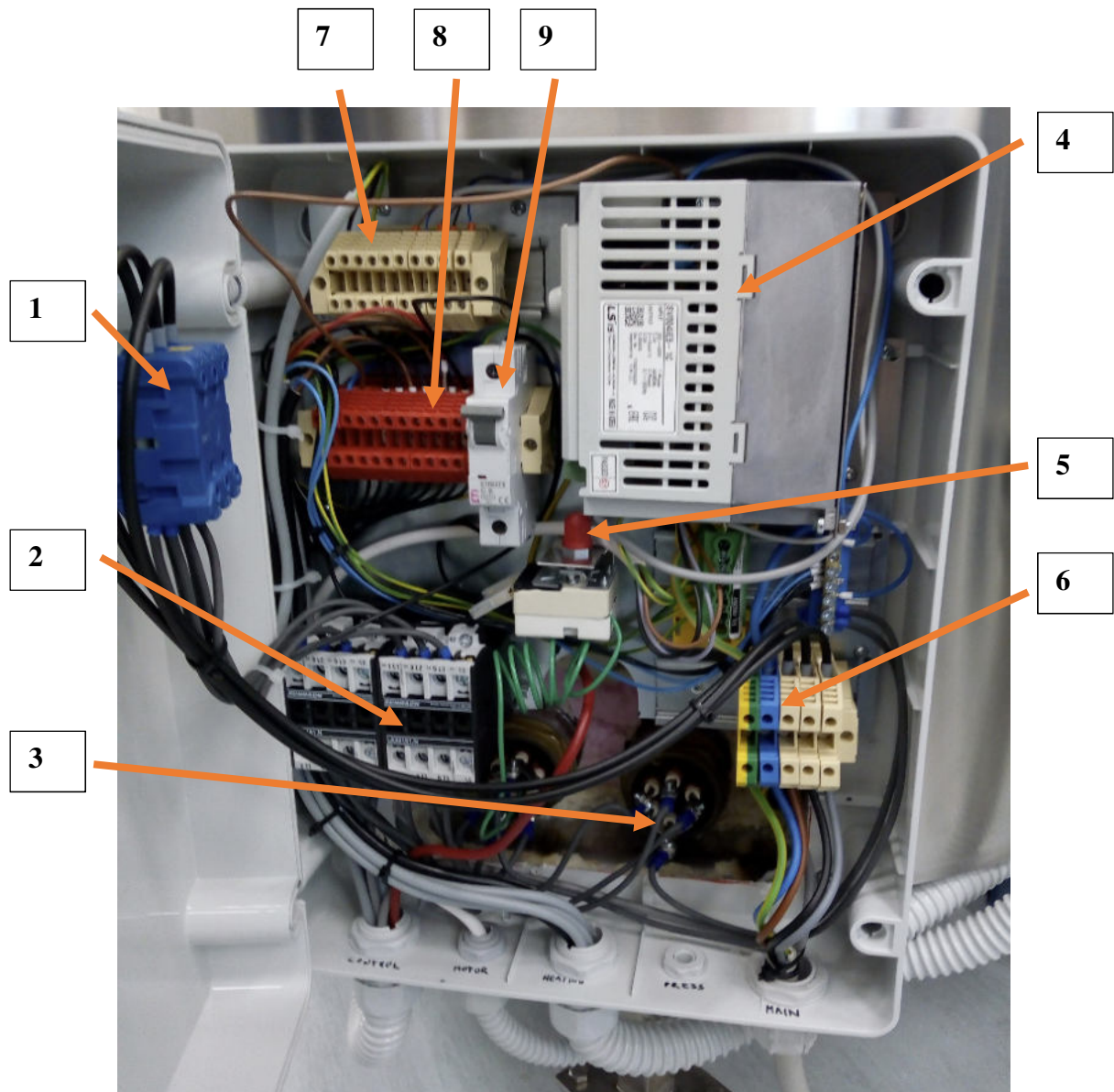

Picture 5

All important parts of Electric case are named and described below:

1. Main switch
2. Contactor for activating the heater
3. Electrical heater
4. Motor speed regulator (Frequency inverter)
5. Thermostat
6. Clips for main electricity
7. Clips for sensors
8. Clips for actuators
9. Fuse for electric elements

Advanced settings menu

The advanced settings menu follows the settings menu and is entered only with a service code. This menu is locked due to safety reasons and can be adjusted only by a credited service partner.

First enter the supplied code to enter the advanced settings menu.

With pressing up key, value is increased by 1 unit.



With pressing down key, value is decreased by 1 unit.



With pressing right key, you switch to another digit.



Water sensor offset adjustments can be made by increasing or decreasing the current temperature value. Pay attention on analog value when changing.

Milk sensor offset adjustments can be made by increasing or decreasing the current temperature value. Pay attention on analog value when changing.

Return water sensor offset adjustments can be made by increasing or decreasing the current temperature value. Pay attention on analog value when changing.

Type of device can be chosen:

- P200 High pressure (closed type devices)
- P200 Low pressure (open type devices)

Cooling factor is a temperature difference between milk and secondary water when device is in cooling phase.

Heating factor is a temperature difference between milk and secondary water when device is in heating phase.

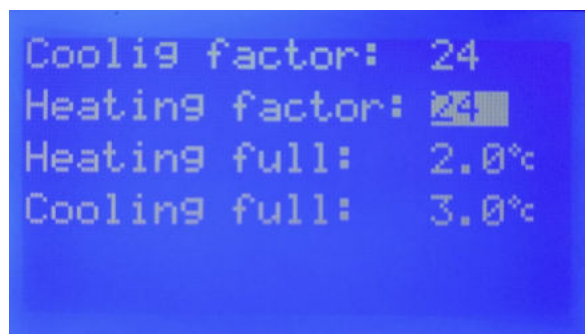
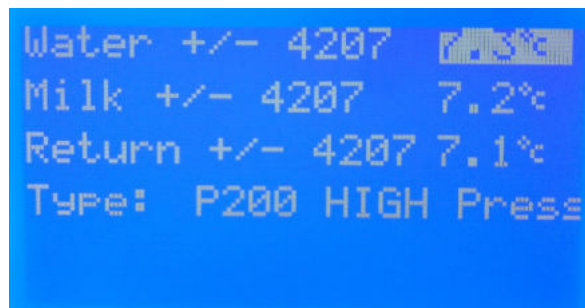
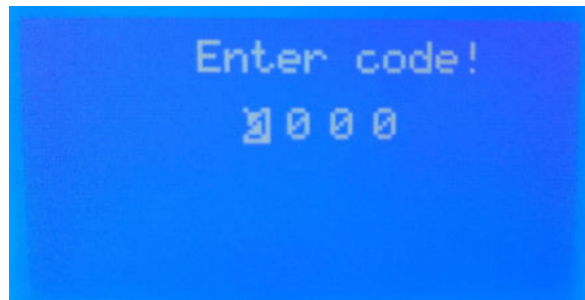

Heating full is a offset in heating phase , where according to setpoint temperature, fine regulation is applied.

Cooling full is a offset in cooling phase, where according to setpoint temperature, fine regulation is applied.

8. DEVICE ASSEMBY AND SPARE PARTS

All important parts of device are named and described below:

1. The kettle
2. Milk outlet valve with knee outlet
3. Two part cover with handles
4. Electric case
5. Controlling cabinet
6. Microprocessor unit
7. Power cord and socket (non European editions come without a socket)
8. Tilting lever (mechanism to lean the kettle when empty)
9. Stable support with wheels
10. Motor cover
11. Rotating motor support
12. Heating unit cover
13. Rotating control box support
14. ON/OFF switch
15. Fixing device for motor support
16. Milk temperature sensor (two temperature probes)
17. Electro heaters

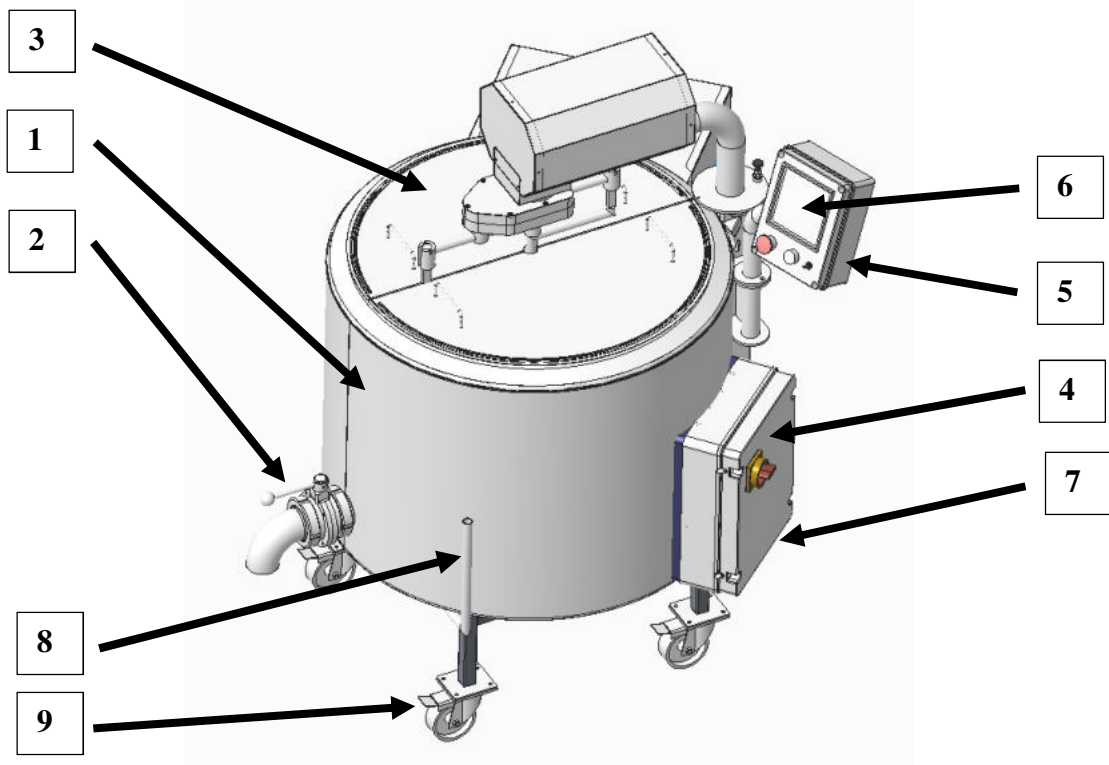

Picture 1

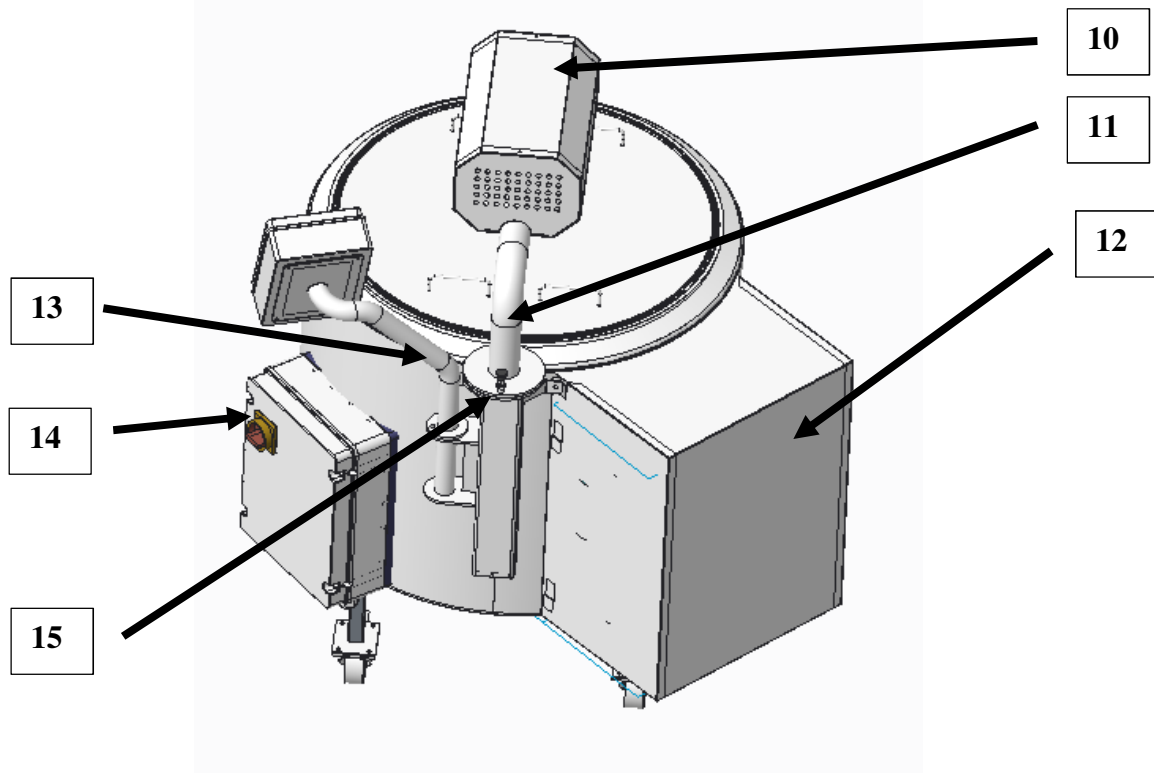

Picture 2

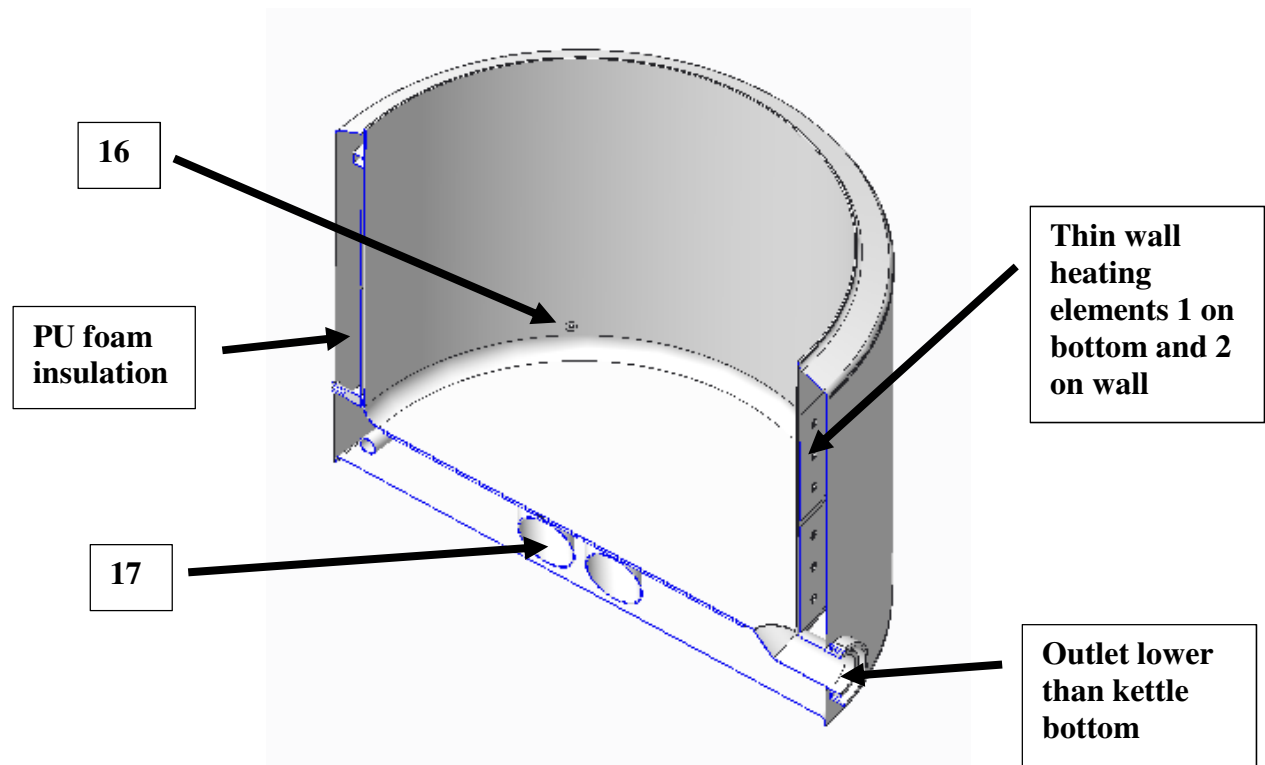

Picture 3



Picture 4

All important parts of heating unit are named and described below:

1. Venting device
2. Expansion vessel
3. Circulating pump
4. Manometer
5. Safety valve for overpressure
6. Manual valve for disconnecting the upper heating element
7. Electronic manometer
8. Plate heat exchanger for cooling water
9. Motor valve for external heating
10. Mixing valve for external heating
11. Solenoid valve for cooling water

Device spare parts list

Pos.	Art. No.	Part name	Kg
1.2		Milk outlet valve with knee outlet	
1.3		Two part cover with handles	
1.6		Microprocessor unit	
1.10		Motor cover	
1.12		Heating unit cover	
1.17		Electro heater	
2.1		Venting device	
2.2		Expansion vessel	
2.3		Circulating pump	
2.4		Manometer	
2.5		Safety valve for overpressure	
2.7		Electronic manometer	
2.8		Plate heat exchanger for cooling water	
2.9		Motor valve for external heating	
2.10		Mixing valve for external heating	
2.11		Solenoid valve for cooling water	
3.1		Main switch 25A	
3.2		Contactator 7,5 kW	
3.2		Contactator 11 kW	
3.3		Electrical heater 6 kW	
3.3		Electrical heater 9 kW	
3.4		Frequency inverter LS le5 400W	
3.5		Thermostat 140°C 16A	
3.9		Automatic Fuse C 6A	

Spare parts ordering procedure

Fast and reliable shipment of spare parts is possible only if their description is clear enough. At the time of ordering please state clearly:

- Type of device
- Serial number printed on label plate at the rear side of device.
- Spare part name and number

9. WARRANTY

- In case of troubles consult with your salesman or call authorized service.
- Equipment is warranted to be free from defects in material and workmanship for a period of 12 months against faulty components and assembly. Our obligation under this warranty is limited to the repair or replacement of the instrument or part thereof, which shall within 12 months after date of shipment prove to be defective after our examination.
- Defects or damages of the device, which are result or improper assembly, use, connection or maintenance are not covered by this warranty.
- The warranty also doesn't cover:
 - Device malfunction due to water or milk inflow,
 - Mains cord,
 - Heating elements and it's actuators (contactors)
 - Repairs done by yourself or by other not authorized people,
 - Transport costs.
- Other rights, that are not mentioned in upper obligations of the manufacturer, especially responsibility for personal injury, are excluded.
- The given technical specifications are valid only when all conditions in this user's manuals are fulfilled.

Dear Customer!

We are sure, you will find that our device is a helpful tool and we believe that it will serve you for a long time without any problems. We hope you will recommend it also to your friends!

Thank you for buying it!